

# Fontaine® Fifth Wheel Ultra LT

## Instructions



- Pre-service and operation
- Coupling instructions
- Inspection & maintenance
- Installation instructions
- Warranty

**FOR YOUR SAFETY USE ONLY GENUINE FONTAINE SERVICE PARTS. USING PARTS THAT DO NOT MEET FONTAINE SPECIFICATIONS WILL VOID WARRANTY.**

Read before mounting or operating fifth wheel.

After fifth wheel is installed these important instructions must be permanently retained in the tractor glove box.

**WARNING!** Failure to follow these instructions could cause a hazardous operating condition resulting in serious personal injury or death.



## Introduction

---



### Warning!

**WARNING!** The visual inspection is required by law. Some improper couplings can pass a “tug test” and sound is not reliable to verify proper coupling. The coupling procedure is not complete without a visual inspection. It is necessary to get out of the tractor and look. Incorrect coupling could cause the trailer to disconnect, possibly resulting in serious personal injury or death.

**WARNING!** When coupling, the fifth wheel must lift the trailer. Always inflate the tractor suspension air bags prior to coupling. Coupling should not be attempted with the tractor suspension air bags deflated. Inflating the tractor suspension air bags while positioned underneath the trailer may result in damage to and incorrect coupling of the fifth wheel, possibly resulting in serious personal injury or death.

**WARNING!** Do not use any fifth wheel that has damaged components or fails to operate properly.

**WARNING!** Failure to follow these specifications will void warranty and could affect product performance.

**WARNING!** Air cylinder(s) should not be disassembled as contents are under pressure.

**WARNING!** Under no circumstances should a sliding fifth wheel be repositioned while the tractor and trailer are in motion. This could result in personal injury or death.

**WARNING!** Do not use a lube plate (high density polyethylene) on top of the fifth wheel or kingpin bolster plate in lieu of grease without prior approval by Fontaine.

### NT IF THE FIFTH WHEEL IS PROPERLY LOCKED – ULTRA LT, ULTRA HD, ULTRA HR, ULTRA iT

Verify secure coupling with a “tug test”, by easing the tractor forward, with the trailer brakes on, to feel resistance of the load. Set the parking brakes on the tractor and trailer and get out of the tractor and visually inspect, using a flashlight if necessary, that the fifth wheel is properly closed.

**The locking jaw and wedge must be fully across the throat of the fifth wheel, there must be no gap between the fifth wheel and the trailer plate, and the pull handle notch must be across the edge of the lock edge guide of the fifth wheel. All three areas of the fifth wheel must be inspected to ensure that the fifth wheel is properly coupled. See figure below. If the visual inspection indicates that you failed to obtain a proper couple, open the fifth wheel, inspect for damaged components, and repeat the coupling sequence.**

**Below are three critical areas of visual inspection that drivers must perform after every couple.**

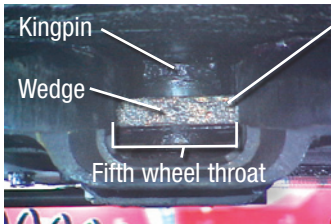

Locking jaw and wedge must be fully across the throat of the fifth wheel



No gap between trailer bottom and fifth wheel

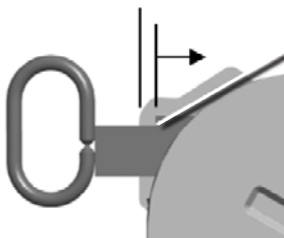

Pull handle notch across plate (see page 13)

# Introduction

---

For over 60 years, Fontaine has been passing customer performance tests by building fifth wheels with innovative technology, uncompromising quality, and features designed to ensure cost-efficient performance.

This handbook provides instructions and recommended procedures to ensure optimum performance from your new Fontaine® Ultra LT fifth wheel.

**Keep this handbook in the tractor glove box after your fifth wheel has been installed.**

For convenience record fifth wheel information below:

Model number: \_\_\_\_\_

Serial number: \_\_\_\_\_

In service date: \_\_\_\_\_

Serial number engraved into the right side of the fifth wheel skirt. Note: position 5 and 6 of the serial number indicates the year built.



If you have any questions concerning your new fifth wheel, our Customer Service Department is available to help you at (800) 874-9780.

<b>Contents</b>	<b>Pages</b>
<b>Section I – Pre-service and operation</b>	<b>5-9</b>
<b>Section II – Coupling instructions</b>	<b>10-17</b>
<b>Section III – Inspection and maintenance</b>	<b>18-20</b>
<b>Section IV – Installation instructions</b>	<b>21-27</b>
<b>Section V – Fontaine limited warranty</b>	<b>28-30</b>

## Section I – Pre-service and operation

Always check for damage due to improper handling or delivery practices prior to starting recommended pre-service procedure.

Prior to service the fifth wheel assembly should be inspected, checked for proper operation and lubricated.

**WARNING!** Do not use any fifth wheel that has damaged components or fails to operate properly.

### A. Fasteners

Make sure all nuts and bolts are in place and properly tightened.

Check all welds for cracks, breaks or separation.

Check to see if both bracket pins are in place and secured by retainer pins and cotter pins.

(see Figure A & B)

**Figure A**

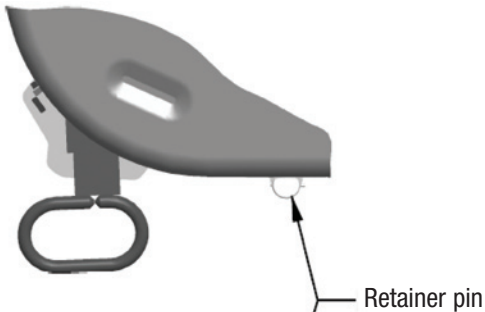

**Figure B**

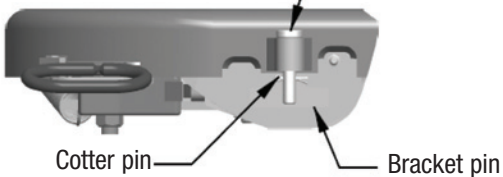

## Pre-service and operation

---

### B. Lubrication

1. Tilt the top plate forward (front of the fifth wheel down) and apply grease to each bearing area through the zerk fitting located on each side of the top plate just to the front and rear of the bracket pins. Continue to apply grease until it is coming out of the back of the bearing. It may be necessary to raise the rear of the fifth wheel with a pry bar to open up the pocket slightly and allow the grease to flow through. Periodically remove the fifth wheel to clean old grease from the bracket grease channels to help insure an even distribution of fresh grease. A substantial amount of grease may be required initially to fill the reservoir. Tilt the wheel to the rear (rear of the wheel down) and repeat the procedure. Rock the top plate back and forth several times to spread the grease over the bearing surface.

Inspect the trailer kingpin plate and top surface of the fifth wheel to make sure each is properly greased. A liberal coating of grease should be applied to the complete surfaces of both the trailer kingpin plate and the top surface of the fifth wheel. A paddle or brush will make this job easier.

**WARNING! Do not use a lube plate (high density polyethylene) on top of the fifth wheel or kingpin bolster plate in lieu of grease without prior approval by Fontaine.**

The additional thickness of this material can prevent the proper operation of the fifth wheel and can cause a dangerous condition.

2. Lubricate the fifth wheel prior to opening and closing. Referring to Figure C (next page), grease the jaw and lockbar (wedge) on top and bottom. Separate the jaw and wedge with a large screwdriver and distribute the grease along the full length of the jaw and wedge mating surfaces. Open and close the fifth wheel several times to further distribute the grease.

Fontaine suggests the use of a moly-based lubricant such as Mobilgrease XHP320 or equivalent when applying lubricant to the locking jaw and wedge. Lightly oil other moving parts in the fifth wheel. (Areas or regions that

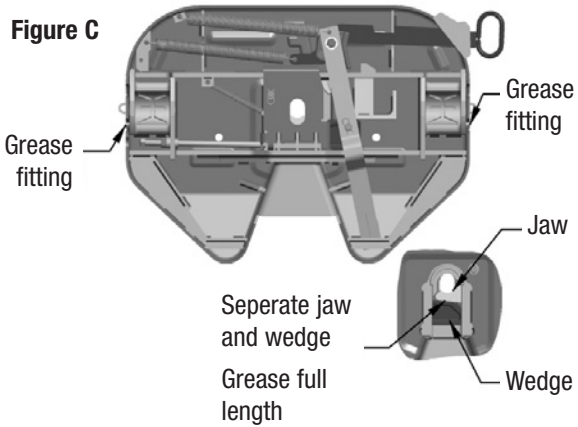

experience extreme and/or prolonged freezing temperatures should consider using a less viscous substance such as: 90-weight oil, diesel fuel, kerosene, motor oil, etc. Fontaine suggests contacting your specific lubricant manufacturer for guidelines on mixing compatibility of any lubricant.)

3. For sliding fifth wheels, lightly oil the locking mechanism. Operate the mechanism (air or manual) several times to ensure it is functioning properly.
4. Grease the top plate. Spread grease all over the mating surface of the top plate. Be sure the grease pockets built into the top plates are full of grease.

For service interval lubrication refer to page 20.

# Pre-service and operation

## C. Operation

1. Fontaine's Ultra LT fifth wheel opens by a straight pull on the release handle until maximum opening stroke is achieved then is moved slightly forward until the handle cut out sets up on the handle block located on the fifth wheel skirt. (see Figure D)
2. Close the locking mechanism using a test kingpin, kit part number KIT-ULTRA-KP. Repeat several times making sure that all moving parts have adequate lubrication.
3. The pull handle grip should always be free of grease or any substance which could prevent a firm grip, causing the handle to slip and possibly resulting in injury.

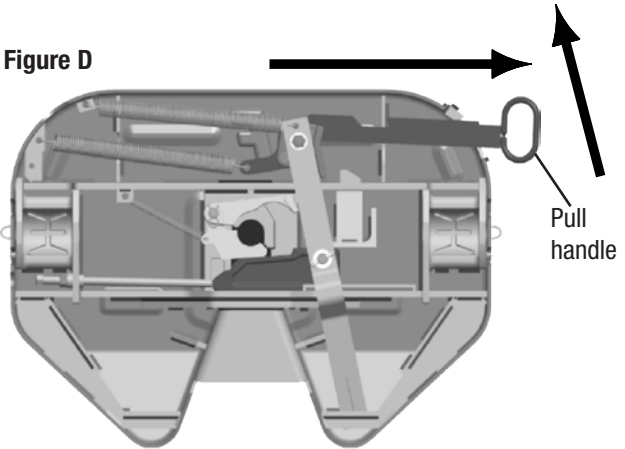

## Adjustment procedure

### Wedge stop rod setting

Wedge stop rod adjustment is not required as part of the pre-service procedure. It is set during the final assembly inspection at our manufacturing facility. Refer to Inspection and Maintenance Procedures section for adjustment procedures and required service intervals.

**This wedge stop can also be used to release a tight wedge (hard to pull handle) by turning the stud clockwise. The adjuster lock nut will need to loosened before turning the stud. Afterwards the fifth wheel should be serviced to adjustment procedure listed on page 19.**

Figure E

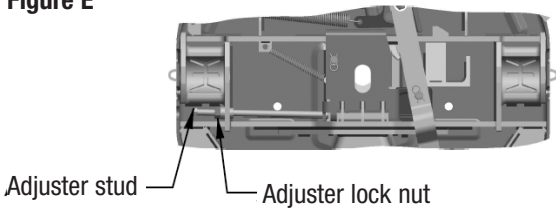

## Section II – Coupling instructions

### Coupling procedure:

1. Prior to coupling, inspect the fifth wheel to ensure a proper operation.

**WARNING! Do not use any fifth wheel that has damaged components or fails to operate properly.**

- Examine the mounting assembly for securely fastened bolts, cracked welds or material separation.
- Tilt the fifth wheel up and down to make sure that it moves freely. Rest the fifth wheel in the proper position by tilting it to the rear of the tractor and resting it on the stops.
- Check the surface for a liberal coating of grease. The indented pockets on top of the fifth wheel act as a grease reservoir for the top surface and should be filled with grease.
- If the tractor is equipped with an air sliding fifth wheel, actuate the air cylinder and check for air leaks. **WARNING: AIR CYLINDER DISASSEMBLY SHOULD NOT BE ATTEMPTED.**
- The fifth wheel should be in an unlocked position (see Figure F). When unlocked, the handle should be extended and the tips of the jaw and lockbar (wedge) visible. **DO NOT TRY TO COUPLE TO A CLOSED FIFTH WHEEL.**

Figure F

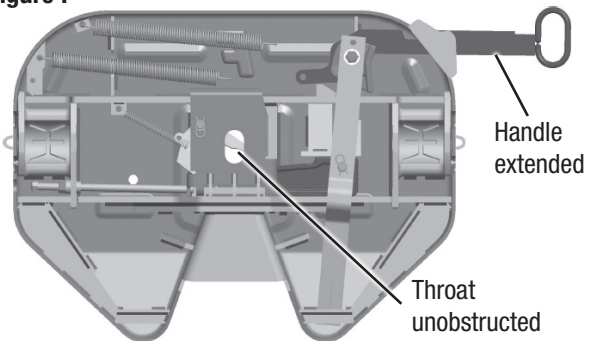

## Coupling Instructions

- The trailer kingpin should be inspected prior to coupling. The kingpin plate should be fully reinforced and of sufficient size to completely cover the fifth wheel. If the kingpin plate is too narrow, the uncovered portion of the fifth wheel will collect dirt and foreign matter. This material may work into the fifth wheel locking mechanism, causing wear and difficulty uncoupling. This material can also cause galling of the fifth wheel and/or kingpin plate.

If the trailer kingpin plate is not fully reinforced, distortion can result causing:

- Non-uniform loading
- Variation in kingpin length
- Cutting and galling of the fifth wheel or kingpin plate

If the trailer kingpin plate is distorted enough to cause any of the conditions listed above, it is recommended that a new plate be installed.

The trailer kingpin plate must be properly greased.

Fontaine fifth wheels are designed and manufactured for use with all trailer kingpins that conform to SAE specifications, SAE J700, February 1993, and subject to the wear limits of SAE J2228, June 1993. These specifications cover SAE 2" (50.8mm) kingpins only.

The SAE standard kingpin can be checked using the dimensions given in Figure G.

**Figure G**  
**SAE standard kingpin (SAE J700, FEB 93)**

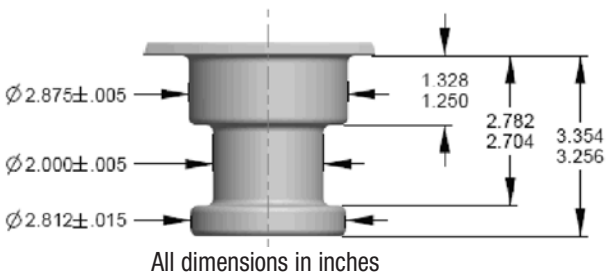

## Coupling Instructions

---

3. Proper tractor/trailer alignment with the tractor directly in front of the trailer is critical to obtain a secure coupling and to avoid equipment damage. Never couple at an angle as it could result to damage to trailer landing legs.

Set the trailer brakes and raise the trailer to the proper height by extending the landing legs. If the trailer is positioned too high, the kingpin may jump the fifth wheel throat and locking mechanism altogether. Resulting damage may include: scoring the fifth wheel, bending the handle thus preventing the fifth wheel from properly locking to the kingpin, bending the kingpin, and other significant damage to the tractor or trailer.

Coupling should not be attempted if the trailer is too low. Costly damage may be incurred to the trailer, the kingpin, the kingpin plate, the fifth wheel, tractor drive train and truck frame.

4. To couple the fifth wheel to the kingpin, be sure the fifth wheel is positioned so that it tilts down at the rear and is resting on the stops.

Align the kingpin with the throat of the fifth wheel and ease the tractor toward the trailer. The trailer should strike the fifth wheel just at the top of the approach ramps. The fifth wheel will level with the kingpin plate and the kingpin should slide into the fifth wheel throat. (see Figure H)

Coupling is complete when the fifth wheel locking mechanism snaps closed behind the kingpin.

**Figure H**  
Fifth wheel  
needs to lift up  
trailer.



**Slowly back into the trailer until  
resistance is felt.**

## Coupling Instructions

Verify secure coupling with a “tug test,” by easing the tractor forward to feel resistance of the load. If the coupling feels secure, visually inspect the fifth wheel. **The jaw and lockbar (wedge) must be locked in place behind the kingpin and the pull handle must be fully retracted and secure in place.** (see Figure I)

After the fifth wheel is properly positioned, inspect the locking wedges to ensure that they are fully engaged in the slide rail pockets.

**Under no circumstances should a sliding fifth wheel be repositioned while the tractor and trailer are in motion.**

**Do not attempt to slide the fifth wheel until all persons are clear of the vehicle.**

**Figure I**

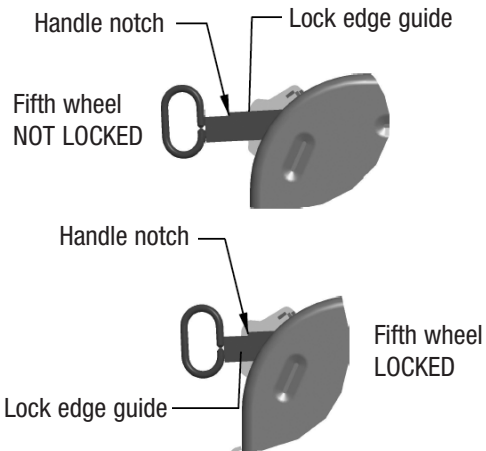

## Coupling Instructions

---

5. To position an air sliding fifth wheel, set the trailer brakes, activate the cab control air valve to allow the air cylinder to retract the locking wedges. Ease the tractor forward or backward to move the fifth wheel to the desired position. Now deactivate the air valve to allow the air cylinder to collapse allowing the locking wedges to lock into position.

Position a manual sliding fifth wheel, by pulling up and out on the pull handle. Drop it outside the handle guide. Ease the tractor forward or backward to position the fifth wheel. Pick up the pull handle and allow it to spring back into a locked position.

**WARNING! When coupling, the fifth wheel must lift the trailer. Always inflate the tractor suspension air bags prior to coupling. Coupling should not be attempted with the tractor suspension air bags deflated.**

**Inflating the tractor suspension air bags while positioned underneath the trailer may result in damage to and incorrect coupling of the fifth wheel, possibly resulting in serious personal injury or death.**



**Warning!**

**The visual inspection is required by law. Some improper couplings can pass a “tug test” and sound is not reliable to verify proper coupling. The coupling procedure is not complete without a visual inspection. It is necessary to get out of the tractor and look. Incorrect coupling could cause the trailer to disconnect, possibly resulting in serious personal injury or death.**

## Coupling Instructions

### HOW TO TELL IF THE FIFTH WHEEL IS PROPERLY LOCKED – ULTRA LT, ULTRA HD, ULTRA HR, ULTRA IT

Verify secure coupling with a “tug test”, by easing the tractor forward, with the trailer brakes on, to feel resistance of the load. Set the parking brakes on the tractor and trailer and get out of the tractor and visually inspect, using a flashlight if necessary, that the fifth wheel is properly closed.

**The locking jaw and wedge must be fully across the throat of the fifth wheel. There must be no gap between the fifth wheel and the trailer plate, and the pull handle notch must be across the edge of the lock edge guide of the fifth wheel. All three areas of the fifth wheel must be inspected to ensure that the fifth wheel is properly coupled. See figures below. If the visual inspection indicates that you failed to obtain a proper couple, open the fifth wheel, inspect for damaged components, and repeat the coupling sequence.**

**Below are three critical areas of visual inspection that drivers must perform after every couple.**

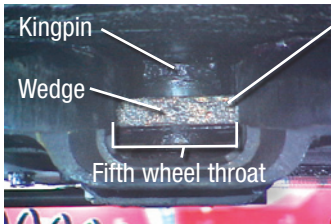

Locking jaw and wedge must be fully across the throat of the fifth wheel

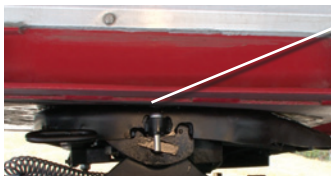

No gap between trailer bottom and fifth wheel

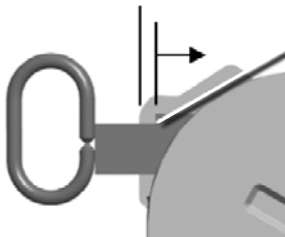

Pull handle notch across plate (see page 13)

# Coupling Instructions

---

## Uncoupling procedure

1. Prior to uncoupling, set the trailer parking brakes.  
Back the tractor gently but tightly against the trailer before setting the tractor parking brake. This will help relieve pressure from the fifth wheel locking mechanism.

**IF THE TRUCK IS EQUIPPED WITH AIR RIDE SUSPENSION, DO NOT DUMP THE AIR BEFORE OPENING THE FIFTH WHEEL. DOING SO MAY CAUSE A HARD TO OPEN SITUATION.**

2. Block the trailer wheels. If poor ground conditions exist, you may have to provide a base for the trailer landing gear.
  - Spring suspension: lower landing gear until it contacts the ground. Give a few extra turns in low gear. **DO NOT** lift the trailer off of the fifth wheel.
  - Air ride suspension: lower landing gear until it contacts the ground. Add one additional turn. **DO NOT** lift the trailer off of the fifth wheel.
3. Disconnect the air and electrical lines.
4. Open the fifth wheel.
5. Release the tractor parking brake and slowly drive the tractor from under trailer. Let the trailer slide down the fifth wheel approach ramps. This will allow the air ride suspensions to adjust to unloaded height.  
**CAUTION: GOING TOO QUICKLY WILL CAUSE THE SUSPENSION TO BOUNCE, POSSIBLY DAMAGING THE TRAILER, TRACTOR FRAME RAILS OR SUSPENSION AIR BAGS.**

# Coupling Instructions

## Slide adjustment



### Warning!

Under no circumstances should a sliding fifth wheel be repositioned while the tractor and trailer are in motion. This could result in serious personal injury or death.

Do not attempt to slide the fifth wheel until all persons are clear of the vehicle.

**Note: The fifth wheel must be in the locked position when changing slide positions.**

To position an air sliding fifth wheel:

1. Set the trailer brakes.
2. Unlock the cab control air valve and allow the air cylinder to retract the locking wedges.
3. Ease the tractor forward or backward to move the fifth wheel to the desired position.
4. Lock the air valve.

After the fifth wheel is properly positioned, inspect the locking wedges to ensure that they are fully engaged in the slide rail pockets. (see Figure J)

**Figure J**



Wedges through rail

**Section III –  
Inspection and  
maintenance procedures**

**WARNING! Do not use any fifth wheel that has damaged components or fails to operate properly.**

Fontaine recommends that preventative maintenance be performed every 90 days or 30,000 miles.

Note: P.M. intervals are recommended based on standard duty applications. Applications more severe than standard duty may require different P.M. intervals to ensure peak performance.

Using a suitable solvent, degrease the fifth wheel and mounting brackets and inspect for:

1. Cracks in the fifth wheel assembly, mounting brackets, and mounting parts.
2. Wear and/or damage to moving parts.
3. Correct operation of the secondary lock.
4. Loose nuts and bolts in the fifth wheel and in the mounting hardware.
5. Securely fastened and properly working springs.
6. Check to see if both bracket pins are in place and secured by retainer pins and cotter pins.
7. Check the locking jaw. If dimension "A" is less than 0.8" (20.25mm) replacement of the jaw and lockbar (wedge) is required. (see Figure K)

**Figure K**

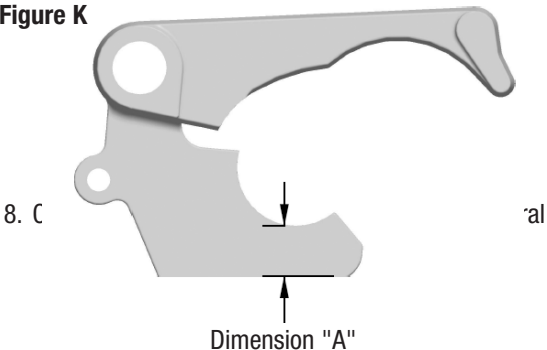

## Inspection and maintenance procedures

coating of grease. If the fifth wheel is equipped with greaseless top plate inserts inspect for damage to mating surfaces.

Check the fifth wheel operation and adjustment. Using a test kingpin, kit part number KIT-ULTRA-KP, follow the instructions provided in the pre-service procedures on page 5-9 of this handbook.

### Adjustment stud procedure

At the first recommended P.M.\* (90 days or 30,000 miles whichever comes first) and every 90 days or 30,000 miles there after, the adjuster stud should be set using criteria listed below.

\* Note: P.M. intervals are recommended based on standard duty applications. Applications more severe than standard duty may require more frequent intervals to ensure peak performance.

1. With the wheel in the closed position, loosen the adjuster jam nut and turn the adjuster stud counter clockwise (outward) until it is free from touching the end of the lock bar (wedge).
2. Insert a test kingpin, kit part number KIT-ULTRA-KP, and ensure the locking mechanism is completely closed.
3. Turn the adjuster stud clockwise (inward) until it contacts the end of the lockbar (wedge). Now turn the adjuster stud clockwise (inward) an additional two and a half complete revolutions. This will give the recommended .02" (0.525 mm) running clearance. (see Figure L)
4. Tighten the adjuster jam nut.

**Improper adjustment can cause the mechanism to bind and/or wear prematurely.**

**Figure L**

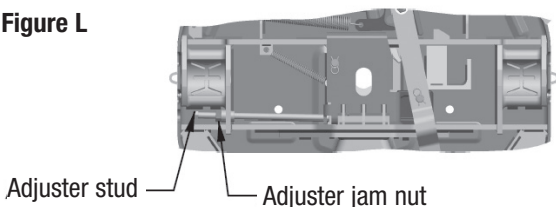

# Inspection and maintenance procedures

---

## Lubrication

Lubrication recommended every 45 days or 15,000 miles.

Follow the instructions provided in the lubrication pre-service procedures on pages 6-7.

**WARNING! Do not use a lube plate (high density polyethylene) on top of the fifth wheel or kingpin bolster plate in lieu of grease without prior approval by Fontaine.**

The additional thickness of this material can prevent the proper operation of the fifth wheel and can cause a dangerous condition.

Special precautions must be taken during cold weather to ensure that the Fontaine® Ultra LT locking mechanism operates freely. Ice and sludge can build up and lubricants become thick and binding at low temperatures. When the temperature drops below freezing, Fontaine recommends a thorough cleaning of the latching mechanism using a suitable cleaner or degreaser to make sure that all moving parts operate freely.

The regular performance of the routine, "90-day/30,000 mile preventative maintenance procedure," is also recommended.

**Fontaine suggests the use of a moly-based lubricant such as Mobilgrease XHP320 or equivalent when applying lubricant to the locking jaw and wedge. Lightly oil other moving parts in the fifth wheel. (Areas or regions that experience extreme and/or prolonged freezing temperatures should consider using a less viscous substance such as: 90-weight oil, diesel fuel, kerosene, motor oil, etc. Fontaine suggests contacting your specific lubricant manufacturer for guidelines on mixing compatibility of any lubricant).**

# Section IV – Installation instructions

### General mounting instructions

1. **Do not** modify and/or customize any fifth wheel or mounting assembly. Modifying or welding to the product will void product warranty. Only Fontaine authorized procedures, such as welding the stop blocks or the rocker limiting blocks are acceptable. Welding must be performed by an AWS certified welder.
2. The fifth wheel should be installed with the pivot point of the fifth wheel located on or ahead of the rear axle or bogie center line. The installation shall be in accordance with DOT regulations, state and local ordinances, SAE and TMC practices and standards, and tractor manufacturers' recommendations.
3. All fifth wheels shall be located so that the tractor and trailer will maintain clearance at all times. On sliding fifth wheels, it may be necessary to "block out" forward locations.
4. All mounting fasteners must be a minimum of:
  - 5/8" (16.0 mm) diameter - Grade 8 bolts
  - 5/8" (16.0 mm) diameter - Grade C lock nuts
  - 5/8" (16.0 mm) diameter - Hardened flat washers
5. Outboard mounting angles shall be ASTM-A-36 or equal with a minimum thickness of 5/16" (8mm).
6. Inboard mounting angles must have a 4" (101.5mm) minimum vertical and horizontal leg and shall not be less than 36" (913.7mm) long. (Stationary angle mounts only)
7. Welding of inboard mounting angles must be performed per criteria shown below.
8. Outboard mounting angles must have a minimum horizontal leg of 3" (76.2mm) and vertical leg of 3-1/2" (88.8mm).
9. The full length, horizontal flange of the outboard mounting angles must be at the **same elevation** as the truck frame. The vertical leg of the angle must fit **flush** with the truck frame. To accomplish this, firmly clamp the fifth wheel and angle in position before drilling the tractor frame. **Warning: Failure to follow these specifications will void warranty and could affect product performance.** (see Figure M)

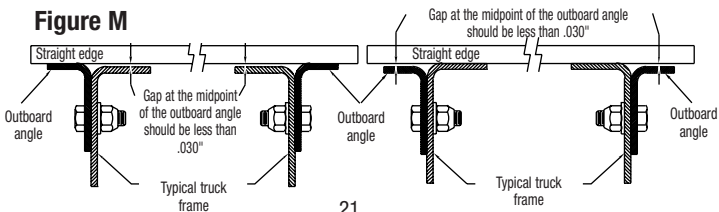

## Installation instructions

- All mounting holes in the truck frame or mounting angles shall be drilled, not burned. All edges and corners shall be ground smooth to prevent point loading. (see Figure N)

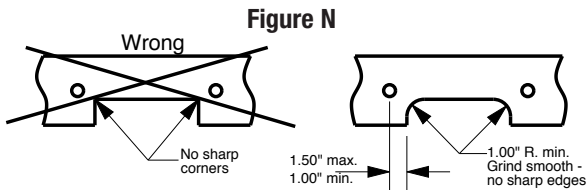

- When required to clear obstructions, cutouts in the mounting angles shall be smooth and straight with a minimum radius of 1" (25.4mm). No sharp corners are permitted and all edges shall be ground smooth. A minimum of two bolts is recommended beyond a cutout.
- Care must be taken to avoid interference or contact between the fifth wheel and air brake modulator when rear of fifth wheel is depressed. In order to prevent this, it is recommended that a stop be attached to the underside of the rear extension of the fifth wheel. The stop should be positioned so that contact is made with the fifth wheel mounting plate.
- Do not** restrict normal rock of fifth wheel. This could create a hazardous operating condition.
- All fifth wheels subjected to weather abuse must be thoroughly cleaned, inspected, and lubricated prior to installation.
- Fifth wheels should be mounted in the proper orientation relative to the tractor. (see Figure O). **Do not** mount the fifth wheel upside down or backward.

**Figure O**

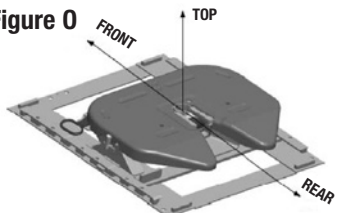

- The trailer that is attached to the fifth wheel should impose a consistent vertical load. Repeated negative loading (trying to pull the fifth wheel off of the brackets with the kingpin) is not allowed. A minimum vertical static load applied to the fifth wheel through the trailer is 10% of the gross trailer weight.
- Do not** center load the fifth wheel. The vertical load should be distributed over the entire surface of the fifth wheel.
- Fixed angle mounts (inboard angles) shall be flush with the top of the truck frame. (no gap between the truck frame and the angle)
- Do not** attempt to "block" Ultra LT fifth wheels.

## Installation instructions

---

### Application/restriction levels\*

**Standard duty:** Fifth wheel must be used in a 100% on-highway application, with more than 30 miles between each stop. The total number of towed axles equals 2. Road type must be maintained concrete or asphalt. Gross Combination Weight (GCW) is less than 95,000 lbs or 43,000 kgs.\*

**Moderate duty:** Fifth wheel must be used in a less than 10% off-highway application, with no minimum mileage between each stop. The maximum total number of towed axles equals 4. Road type must be maintained concrete, asphalt, gravel, or crushed rock. Gross Combination Weight (GCW) is less than 115,000 lbs or 52,000 kgs.\*

**Severe duty:** Fifth wheel can be used in any off-highway application, with no minimum mileage between each stop. The total number of towed axles equals 5 or more. All road types are acceptable including hard packed dirt and non-maintained roads. Gross Combination Weight (GCW) is more than 115,000 lbs or 52,000 kgs.\*

**\* Note: See Fontaine application guide LT-076 for specific application recommendations. Product used in unapproved application voids manufacture warranty.**

### Important application notes:

1. If any single restriction factor within your application is surpassed within a given duty level, the next duty level must be selected.
2. When selecting a fifth wheel, if the application or vehicle usage places the maximum capacity on a certain fifth wheel, then the selection of a fifth wheel with a higher capacity is advised. For example, a tractor that is at a maximum vertical load of 50,000 lbs in a moderate duty application should be using a fifth wheel with a vertical load capacity of 55,000 lbs or greater. This additional capacity should provide better service life over a longer period of time.
3. All logging, mining, oil field and similar applications are considered severe duty. Do not select assemblies in the standard or moderate levels when a special application is designated.

# Installation instructions

## Air slide bracket (LW0)

Adjustment of 24" mounting slide shown. Assemblies with greater adjustment require longer angle and additional mounting bolts. See suggested price list for angle sizes and lengths available. The full length of the horizontal flange of the outboard mounting angles must be at the **same elevation** as the truck frame. The vertical leg of the angle must fit **flush** with the truck frame. (see Figure M on page 21)

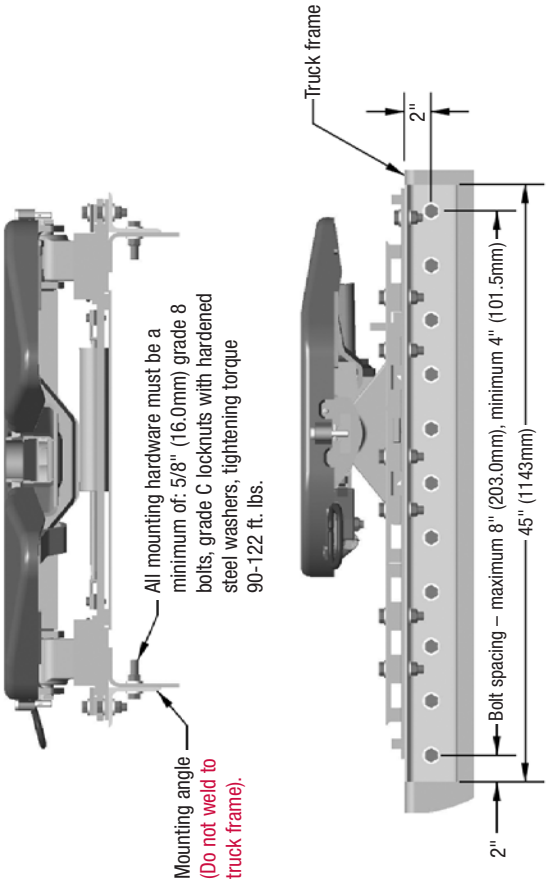

# Installation instructions

## Air slide bracket (LWI)

Adjustment of 24" mounting slide shown. Assemblies with greater adjustment require longer angle and additional mounting bolts. The full length of the horizontal and vertical legs of the angles must fit **flush** with the truck frame. (see Figure M on page 21)

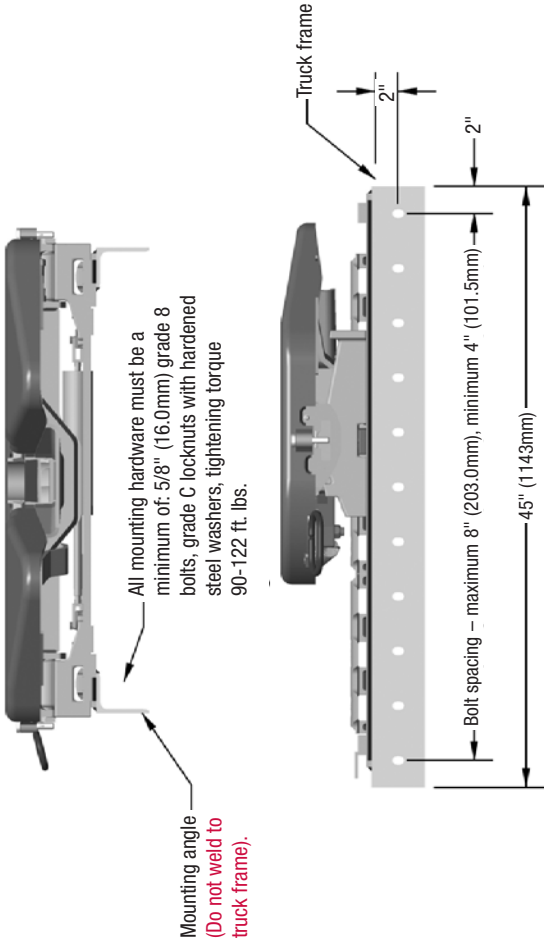

# Installation instructions

## Inboard air slide bracket – welding locations

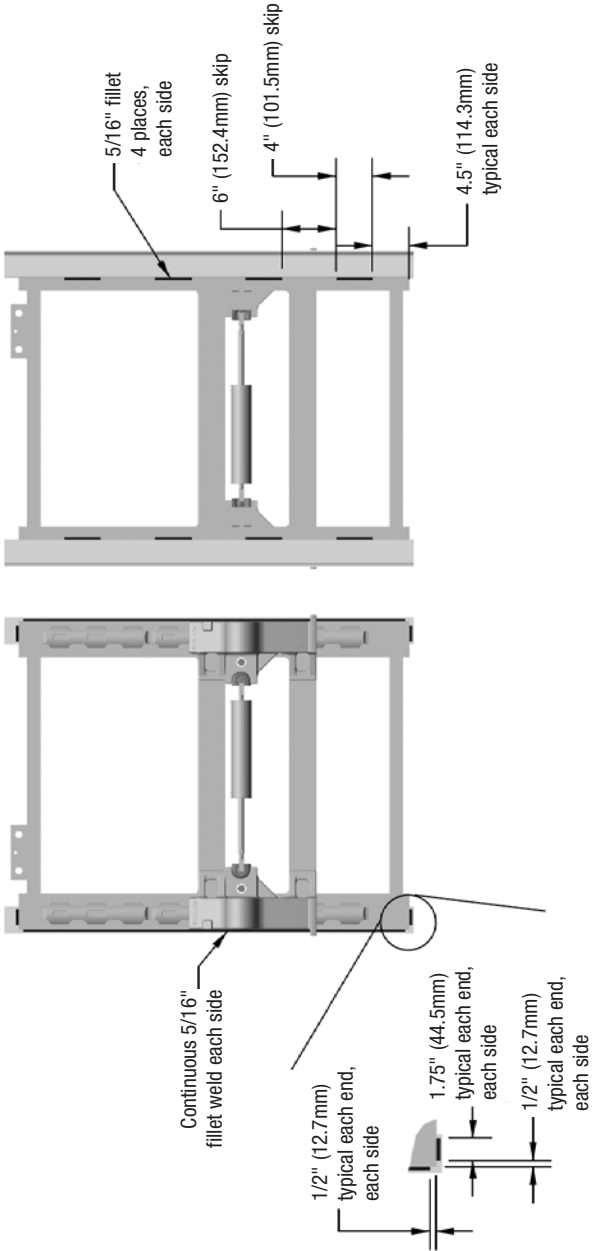

# Installation instructions

## Adjustable plate mounting bracket (APB)

Mounting of 18" adjustable mounting bracket shown. See suggested price list for angle sizes and lengths available. The full length of the horizontal flange of the outboard mounting angles must be at the **same elevation** as the truck frame. The vertical leg of the angle must fit **flush** with the truck frame. See Figure M on page 21.

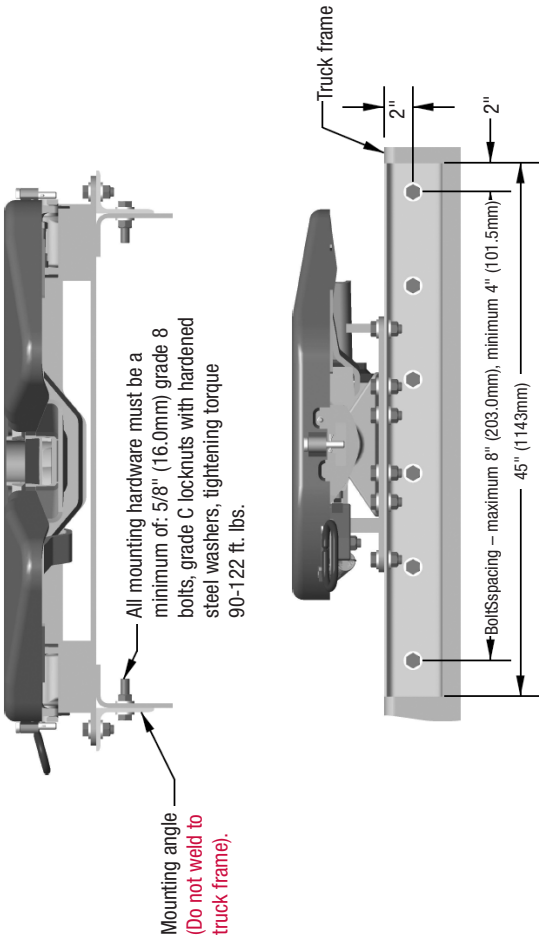

## **Section V – Fontaine limited warranty**

### **Basic limited warranty**

Fontaine Fifth Wheel Company (“Fontaine”) warrants each fifth wheel sold in North America on or after January 1, 2010 to be free from defects in material and workmanship for five years from the date of sale with the exception of Blocked and Xtra Heavy Duty fifth wheels which are warranted for two years.

This warranty does not cover failures due to:

1. Use in loads that are beyond federal and state highway limits or in special overweight load permits.
2. Improper installation of the fifth wheel. (see appropriate Fontaine instruction handbook for proper installation procedures)
3. Normal wear.
4. Accident.
5. Improper application. **See Fontaine application guide LT-076 for specific application recommendations. Product used in unapproved applications voids manufacture warranty.**
6. Misuse, alteration or negligence.
7. Failure to properly maintain the fifth wheel (see appropriate Fontaine instruction handbook for proper installation procedures).
8. Inadequate repairs or alterations that, in Fontaine’s judgment, adversely affect the fifth wheel’s performance or reliability.

Fontaine cannot guarantee the service life of any fifth wheel since service life can vary with application, usage, maintenance, environment, and other factors beyond Fontaine’s control.

## **Fontaine limited warranty**

---

### **Limited performance warranty**

Fontaine warrants the performance of each fifth wheel sold in North America on or after January 1, 2010 that is used in a "standard duty application" for five years from the date of sale. A "standard duty application" requires that (i) the vehicle is used 100% on highways with more than 30 miles (48.3 kilometers) between each stop, (ii) the vehicle does not exceed a gross combined vehicle weight of 95,000 lbs (43,000 kgs), (iii) the total number of towed axles does not exceed two and (iv) the road type is maintained concrete or asphalt.

Fontaine warrants that each fifth wheel covered hereunder shall operate as described in the Fontaine Instruction Handbook, and the locking mechanism (jaw & wedge) will wear properly on the trailer kingpin when the fifth wheel is adjusted in accordance with the manufacture specifications.

Fontaine fifth wheels are designed and manufactured for use with SAE 2" trailer kingpins that conform to SAE specification (SAE J700, February 1993) and are subject to the wear limits of SAE specification (SAE J2228, June 1993).

### **Lube free specific warranty**

Fifth wheel lube free components are warranted for two years unlimited mileage per "standard duty application" requirements as listed.

### **Replacement of parts and repairs**

Authorization from Fontaine must be obtained before replacing or returning any part under this Limited Warranty. **All request for reimbursement must be submitted within 45 days of the repair.**

If the fifth wheel does not perform as warranted in this Limited Warranty, or if there is any defect in the material or workmanship covered by this Limited Warranty, Fontaine will, at its option, provide buyer with parts or reimburse the buyer for parts at its reasonable acquisition cost, up to the amount of the original suggested retail price. Further, Fontaine will cover labor cost in repairing the fifth wheel as long as the labor rate is reasonable and the repair time does not exceed

## Fontaine limited warranty

---

Fontaine's Standard Rate Time chart. Fontaine may require the unit or part to be returned to Fontaine's factory or a Fontaine authorized representative for evaluation. All freight to and from Fontaine or a Fontaine authorized representative must be prepaid.

**This is Fontaine's only warranty (Excludes Custom Duty fifth wheel warranty). Fontaine makes no other warranty of any kind, expressed or implied. All implied warranties or merchantability and/or fitness for a particular purpose are hereby disclaimed by Fontaine and excluded.** This Limited Warranty may not be changed except in writing by an authorized officer of Fontaine. Any action for any alleged breach of this Limited Warranty must be commenced within one year after such alleged breach occurred or shall be forever barred.

The remedies stated above shall be exclusive for any and all claims by the original user, or anybody claiming through the original user, against Fontaine, whether based on contract, negligence, tort, or any other theory. **In no event shall Fontaine be liable for any incidental or consequential damages, losses, or expenses.**

This limited warranty gives the buyer specific legal rights, and buyer may also have other rights, which may vary depending on the state, province or country where the truck is registered.

**For sales and service locations or for additional copies of this handbook go to our web site at [www.fifthwheel.com](http://www.fifthwheel.com) or contact Customer Services at 1-800-874-9780.**

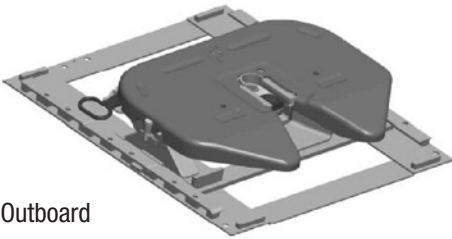

Outboard



Inboard



Fontaine Fifth Wheel  
7574 Commerce Circle • Trussville, AL 35173 USA  
800.874.9780 • Fax 205.655.9982  
[www.fifthwheel.com](http://www.fifthwheel.com)

©2012 Fontaine Fifth Wheel • LT-149 • Revised January 2012  
All specifications are subject to change without notice.